

Numerical analysis of composite piled raft with cushion subjected to vertical load

Fa-Yun Liang^{a,*}, Long-Zhu Chen^a, Xu-Guang Shi^b

^a*Institute of Disaster Prevention, School of Civil Engineering and Mechanics, Shanghai Jiaotong University, Shanghai 200030, PR China*

^b*Department of Civil Engineering, Hong Kong University of Science and Technology, Hong Kong, PR China*

Received 17 October 2002; received in revised form 7 March 2003; accepted 21 March 2003

Abstract

In order to mobilize shallow soil to participate in the interaction of piled raft foundation sufficiently, the authors extended the concept of piled raft to a new type of foundation named composite piled raft. In the system of composite piled raft, the short piles made of flexible materials were used to strengthen the shallow soft soil, while the long piles made of relatively rigid materials were used to reduce the settlements and the cushion beneath the raft was used to redistribute and adjust the stress ratio of piles to subsoil. Finite element method was applied to study the behavior of this new type of foundation subjected to vertical load. Influencing factors, which include ratio of length to diameter and elastic moduli of piles as well as thickness and elastic modulus of cushion, were studied in details. Load-sharing ratios of piles and subsoil as well as foundation settlement were also investigated in this paper. The conclusions had been successfully applied to some practical buildings in the coastal cities of China. The validity of the numerical results was examined through a seven-story building observed in situ.

© 2003 Elsevier Ltd. All rights reserved.

Keywords: Piles; Raft; Foundation; Analysis

1. Introduction

In traditional foundation design, it is customary to consider first the use of shallow foundation such as a raft (possibly after some ground-improvement methodology performed). If it is not adequate, deep foundation such as a fully piled foundation is used instead. In the former, it is assumed that load of superstructure is transmitted to the underlying ground directly by the raft. In the latter, the entire design loads are assumed to be carried by the piles [1]. In recent decades, another alternative intermediate between shallow and deep foundation, what is called piled raft foundation or settlement reducing piles foundation, has been recognized by civil engineers.

The concept of piled raft foundation was firstly proposed by Davis and Poulos in 1972, since then it has been described by many authors, including Burland et

al. (1977), Cooke (1986), Chow (1987), Randolph (1994), Horikoshi and Randolph (1996), Ta and Small (1996), Kim et al. (2001), Poulos (2001), and many others [1–9]. Now the piled raft concept has been used extensively in Europe and Asia. In this concept, piles are provided to control settlement rather than carry the entire load. Piled raft foundation has been proved to be an economical way to improve the serviceability of foundation performance by reducing settlement to acceptable levels. The favorable application of piled raft occurs when the raft has adequate loading capacities, but the settlement or differential settlement exceed allowable values. Conversely, the unfavorable situations for piled raft include soil profiles containing soft clays near the surface, soft compressible layers at relatively shallow depths and some others [1]. In the unfavorable cases, the raft might not be able to provide significant loading capacity, or long-term settlement of the compressible underlying layers might reduce the contribution of raft to the long-term stiffness of foundation. However, most of economically developed cities, especially in Shanghai Economic Circle of China, are located in coastal areas. In these areas, the piled raft concept

* Corresponding author. Tel.: +86-21-6293-2102; fax: +86-21-6293-3082.

E-mail addresses: fyliang@sjtu.edu.cn (F.-Y. Liang), lzchen@sjtu.edu.cn (L.-Z. Chen).

is unfavorable as mentioned above because building construction often meets with deep deposit soft soil. In order to take advantage of piled raft foundation, civil engineers have developed many methods to practice it in China [10]. Based on the engineering practices, the authors develop the concept of piled raft foundation to long-short composite piled raft foundation with intermediate cushion (For short as “composite piled raft”) as is shown schematically in Fig. 1. In this new type of foundation, short piles made of relatively flexible materials such as soil–cement columns or sand–gravel columns (also called sand–stone columns in China), etc. are applied to improve the bearing capacity of shallow natural subsoil; the long piles made of relatively rigid materials such as reinforced concrete are embedded in deep stiff clay or other bearing stratum to reduce the settlement; and the cushion made of sand–gravel between the raft and piles plays an important role in mobilizing the bearing capacity of subsoil and modifying the load transfer mechanism of piles [11]. The advantages of different ground-improvement methodologies may be used fully.

Many theories concerning the analysis of piled raft foundation have been proposed by various researchers [1]. However, most of them do not incorporate the effect of cushion in the analysis and all the piles have the equal length. Composite piled raft is so complex that the analytical approach cannot be used to deal with. But it is well known that the finite element method is very versatile for studying complex problems. In order to clarify behavior of the new type of foundation, especially the influences of cushion, the authors resort to three-dimensional finite element method. This paper presents the factors influencing to the behavior of the proposed foundation, which include ratio of length to diameter and elastic moduli of piles, thickness and elastic modulus of cushion, etc. Load-sharing ratios of piles and subsoil as well as settlement of foundation are also investigated herein. Composite piled raft has been

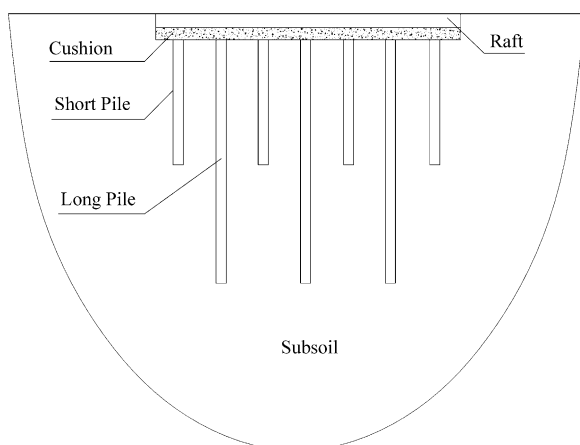

Fig. 1. Sketch of composite piled raft foundation.

successfully applied to some practical buildings in China. A case history of a seven-story building employing composite piled raft proposed by the authors is introduced to validate the numerical results of this paper.

2. Method of analysis

2.1. Model for numerical analysis

The geometry of composite piled raft analyzed in present study was illustrated in Fig. 2. The analysis method refers to three-dimension finite element method proposed by Ottaviani [12]. It is implemented via a computer program ANSYS (a universal computer program for finite element analysis developed by ANSYS Inc. of USA). Because most foundation is in elastic state under common working load conditions, the raft, cushion, piles and subsoil are all assumed to be weightless linearly elastic media. No relative displacements are allowed at the interfaces between the piles and subsoil. The piles have been given as square section for dividing element grids conveniently. The side width of piles, the spacing between the piles and the raft dimensions have been kept constant with values chosen among the widely used in practice.

In the analysis, the long piles and raft are made of concrete; the short piles and cushion are made of sand–gravel. To simplify the analysis, let the side width of long and short piles be equal, $d_1 = d_2 = d = 0.45$ m. Considering that the spacing between short piles is usually small, let $s = d$, where “ s ” is the net spacing between adjacent piles (shown in Fig. 2). Compared with the subsoil, the raft is assumed relatively rigid with elastic modulus $E_c = 3 \times 10^4$ MPa, Poisson’s ratio $\mu_c = 0.2$, side width $B = 6d = 2.7$ m and thickness $h = 0.5$ m. In this paper, these values are used unless otherwise specified. The elastic moduli and Poisson’s ratios of long piles, short piles, subsoil and cushion are listed in Table 1.

Fig. 3 shows a quarter of the three-dimensional finite element scheme, which considers the symmetry of the problem in the analysis. A maximum of 6500 nodes and 4700 “eight-node isoparametric brick” elements are employed to represent the model analyzed. The concerned geometric domain and element grid are determined on the base of trial calculation method. The criteria for them are listed as follows:

1. The calculated results of stresses and displacements distribution do not change apparently with the further expansion of concerned domain.
2. The size of elements in the zones of high stress gradient should be as small as possible while the size of elements around the domain boundary could be larger.

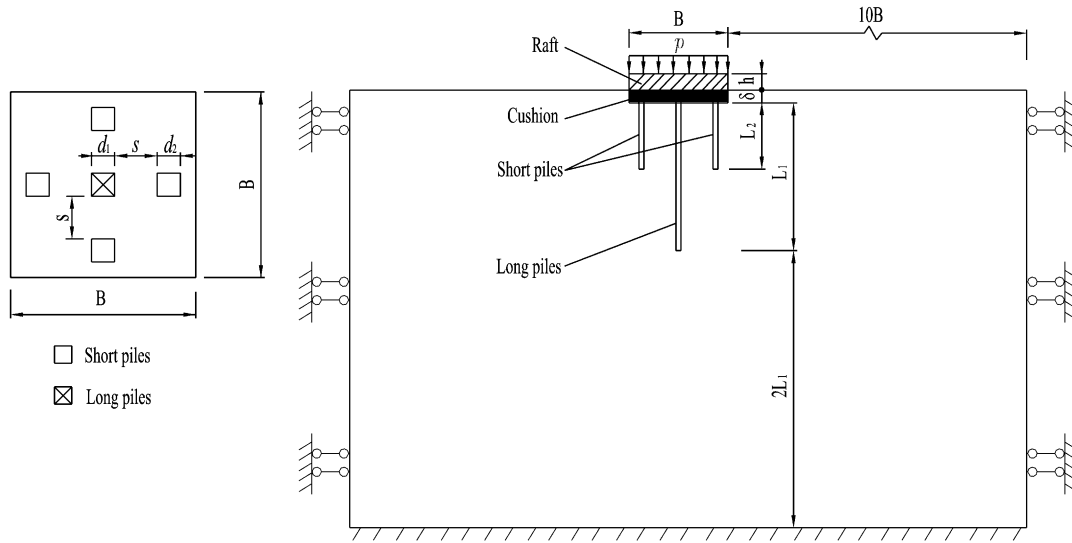

Fig. 2. Schematic diagram of calculating modal to be analyzed.

Table 1
Parameters of materials for analysis

Material	Long piles	Short piles	Subsoil	Cushion
Elastic modulus/MPa	$E_{p1} = (1 \sim 3) \times 10^4$	$E_{p2} = 100 \sim 2500$	$E_s = 5$	$E_m = 10 \sim 80$
Poisson's ration	$\mu_{p1} = 0.20$	$\mu_{p2} = 0.30$	$\mu_s = 0.35$	$\mu_m = 0.30$

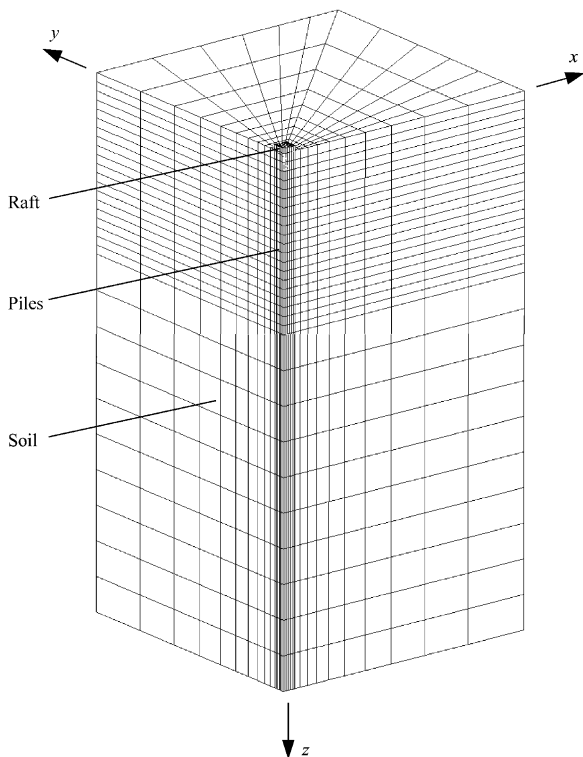

Fig. 3. Finite element schematic of composite piled raft system.

According to the criteria, the trial calculation result shows that the bottom boundary should be set in depth of $3L_1$ from the head of piles (L_1 is the length of long pile) and be treated as fixed boundary, while the lateral surrounding boundary should be located at the place which is $10B$ (B is the width of square raft) to the raft edge and be treated as vertically sliding but horizontally restrained.

The comparisons between the present FEM and Boussinesq's solution are listed as Table 2. The calculating model is same as the above except that the piles are replaced by soil. In the analysis, $E_s = 5$ MPa, $\mu_s = 0.35$, $B = 2.7$ m, $p = 100$ kPa (uniformly acted on the raft), and the origin of coordinate is at the center of the raft. The comparisons show that the errors between the present FEM and Boussinesq's solution are $< 4\%$, which indicating that the present method has adequate accuracy.

2.2. Non-dimensional parameters for numerical study

The main influencing factors include material parameters of piles, cushion, subsoil and the length of piles and the spaces of piles and others. In order to simplify the analysis and summarize the rules from the calculating

Table 2
Comparisons between the present FEM and Boussinesq’s solution

Solution category	Vertical stress/kPa				Vertical displacement /mm
	(0, 0, 0.55B)	(0, 0, 2.13B)	(0.5B, 0, 0.55B)	(0.5B, 0, 2.13B)	
Coordinate position					(0, 0, 0)
FEM solution	67.18	10.13	36.95	8.29	51.3
Boussinesq’s solution	65.20	9.77	38.12	8.63	53.1
Error	3.04%	3.68%	−3.07%	−3.94%	−3.39%

results, several dimensionless parameters are introduced below:

1. $k_1 = E_{p1}/E_s$, which is the elastic modulus ratio of long piles to subsoil;
2. $k_2 = E_{p2}/E_s$, which is the elastic modulus ratio of short piles to subsoil;
3. $k_3 = E_m/E_s$, which is the elastic modulus ratio of cushion to subsoil;
4. $K = \frac{P}{wE_s d^2}$, which is the dimensionless stiffness of composite piled raft system, where P is the total load acted vertically on the raft, w is the average settlement of the raft.
5. η_1, η_2, η_3 , which are the load-sharing ratios of long piles, short piles and subsoil under the raft respectively.

3. Behavior of composite piled foundation without cushion

In order to clarify the behavior of long–short composite piled raft foundation, the cushion is not concerned at this section. As to the composite piled raft foundation shown in Fig. 2, $\delta=0$, $E_{p1} = 10^4\text{MPa}$, $k_1=2000$,

and $p=100\text{ kPa}$ (the uniform load acted on raft). In practical engineering, long piles are usually made of rigid materials such as concrete or steel with narrow range of elastic modulus. So changing elastic modulus of long piles is hardly used to adjust the settlement of foundation. Therefore, only changing elastic modulus of short piles made of sand–gravel or soil–cement is discussed. At the same time, the ratio of pile length to diameter is also considered.

3.1. Characters of foundation settlement

Fig. 4 (a) shows the relation between K (the dimensionless stiffness of composite piled raft system) and k_2 (the elastic modulus ratio of short pile to subsoil) with $l_2/d=10$ and variable l_1/d . Fig. 4(b) shows the relation between K and k_2 with $l_1/d=50$ and variable l_2/d . Because of P , E_s and d keep constant, K is in inverse proportion to w (the average settlement of raft). Therefore, it can be derived out that:

- 1 Increasing only the elastic modulus of short piles will improve the stiffness of the composite piled raft system and reduce its settlement. However, when k_2 reaches a certain value, the increasing rate of K becomes quite small and the effect on

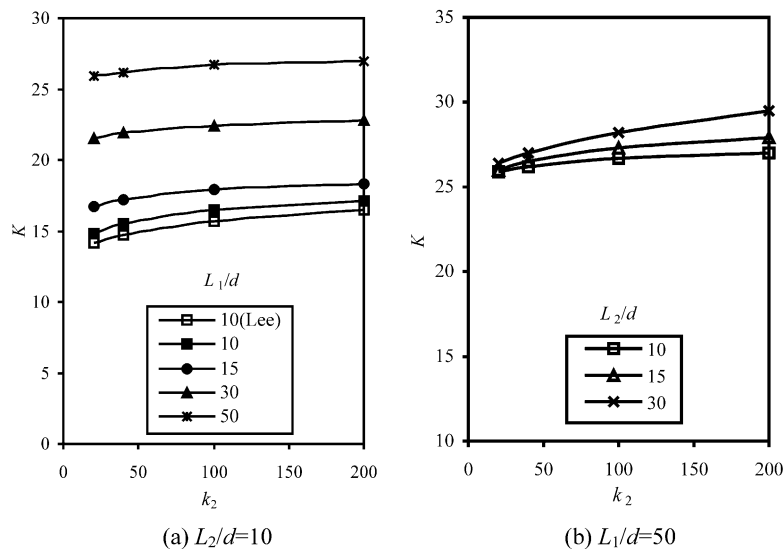

Fig. 4. Variations of K with k_2 .

reducing the settlement of raft becomes not obvious. Therefore, there is an optimum k_2 for reducing settlement with the least cost. It is also a valuable conclusion for the design of the conventional piled foundation.

- 2 In given elastic moduli of long and short piles, increasing the lengths of long piles or short piles will enhance the stiffness of the piled raft system, in which the influence of long piles is much more apparent. So increasing the length of long piles is much more favorable for reducing the settlement of raft.
- 3 When the length of short piles is given and much shorter than that of long piles, increasing the elastic modulus of short piles has few effects on reducing the settlement of raft. However, when the length of short piles is rather close to that of long piles, increasing the elastic modulus of short piles is quite effective.
- 4 When the lengths of the short and long piles are the same ($L_1/d = L_2/d = 10$), a comparison between Lee’s method [13] and the present FEM is also included in Fig. 4(a). For calculating the stiffness K with Lee’s method more reasonably, the piles–raft–soil interaction is also considered with Chow and Teh’s method [14]. It can be seen that the present method is fairly well consistent with the approximate analytical method.

3.2. Properties of load-sharing ratios of piles and subsoil

Fig. 5 shows the relations among load-sharing ratios of piles and subsoil, elastic modulus of short piles and the length of long piles. In the analysis, the length of short piles keeps constant ($l_2/d = 10$). Some conclusions can be drawn out from Fig. 5.

1. The load undertaken by short piles increases with the increasing of elastic modulus of short piles, while the loads carried by long piles and subsoil decreases correspondingly. However, when the

elastic modulus of short piles comes to a certain value, these changes will be no longer obvious.

2. The influence of short piles’ elastic modulus on the load-sharing ratios of piles will become not sensitive with the increasing of the length of long piles. It means that the stiffness of short piles has few effects on the load-sharing ratios of piles when the length of long piles is much larger than that of short piles.
3. When the length of short piles is given, the load undertaken by long piles increases with the increasing of the length of long piles, while that undertaken by short piles and subsoil decreases correspondingly.

4. Effects of cushion on the properties of composite piled raft

Practise shows that sand–gravel cushion between the raft and piles can adjust the load-sharing ratios of piles and subsoil, and enhance the strength of subsoil among piles. Particularly, the thickness of cushion and the elastic modulus of cushion have important influences on the properties of composite piled raft foundation. Some researchers have studied the effects of cushion on the properties of raft foundation [11,15], while no studies were aimed at composite piled raft system proposed in this paper.

4.1. General effects of cushion on the properties of composite piled raft

In calculation, $\delta = 0.3$ m, $E_m = 80$ MPa (equivalent to $k_3 = 16$), $\mu = 0.3$, $E_s = 5$ MPa, $k_1 = 2000 \sim 3000$, $k_2 = 40$, $L_1 = 54d = 24.3$ m, $L_2 = 26d = 11.7$ m, and other parameters are the same as the above. When the uniform load acted on the raft is $p = 100$ kPa, the mean axial stress in each pile and the mean vertical superimposed stress of soil among piles varied with depth are shown in Fig. 6. Some rules can be drawn out from Figs. 6 and 7.

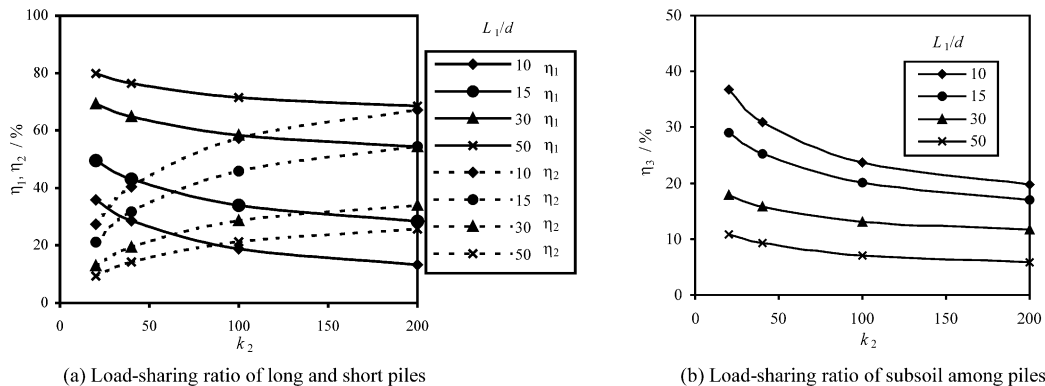

Fig. 5. Load-sharing ratio of piles and subsoil varied with k_2 .

1. The axial stress of long piles in composite piled raft foundation with cushion are smaller than that of foundation without cushion, while the axial stress of short piles in composite piled raft foundation with cushion are larger than that of foundation without cushion. Thus it shows that cushion can adjust the load-sharing ratios evenly among piles and help to make better use of the bearing capacities of short piles.
2. In composite piled raft foundation without cushion, the maximum axial stress occurs at the head of piles and axial stress of piles decreases along the depth. However, these properties have changed after installed cushion between piles and raft. Compared with the foundation without cushion, the maximum axial stress of piles shifts lower from the head of piles to a certain depth. It is because that the load undertaken by subsoil increases under the adjustment of cushion and the displacements of subsoil are larger than that of piles in a range of certain depth along piles shaft (shown in Fig. 7). And then the negative friction is generated by the relatively larger settlement of shallow subsoil. However, when the depth is lower than the certain depth, the displacements of piles are larger than that of subsoil with the further increasing of depth, and the friction along piles will become positive and then the axial stress of piles decreases with the depth again.
3. The change of superimposed stress of subsoil mainly occurs in the shallow subsoil, though the load-sharing ratio of subsoil is improved after cushion installed. It is the result of deformation compatibility among long piles, short piles and subsoil. Thus it can be seen that the bearing capacities of shallow subsoil can be better used through appropriate application of cushion

technique, especially for ground containing hard crust in shallow layers.

4.2. Effects of elastic modulus of cushion on the properties of composite piled raft

In order to study the influence of elastic modulus of cushion, let $E_m = 10 - 80$ MPa (equivalent to $k_3 = 2-16$), $\delta = 0.3$ m, $k_1 = 5000$ and $k_2 = 40$ with other parameters the same as the previous. Fig. 8 shows the axial stress of piles changes with elastic modulus of cushion. Fig. 9 shows that the superimposed stress of subsoil on the surface of foundation as well as the vertical stress ratios of piles to subsoil change with the elastic modulus of cushion. Some rules can be drawn out from Figs. 8 and 9.

1. At a given thickness of cushion, the lower the elastic modulus of cushion, the smaller the axial stress of long piles, but the greater the axial stress of short piles and the superimposed stress of subsoil. Correspondingly, the vertical stress ratio of long piles to subsoil decreases obviously with the reduction of the elastic modulus of cushion, especially when the elastic modulus of cushion is lower than 40 MPa. Whereas the stress ratio of short pile to subsoil approximately does not change. It means that decreasing the elastic modulus of cushion can both decrease the stress concentration of long piles and mobilize the bearing capacity of short piles and subsoil sufficiently.
2. It can also be seen that the lower the elastic modulus of cushion, the deeper the location of the maximum axial stress of long piles. While to short piles, the location of the maximum axial stress almost does not change.

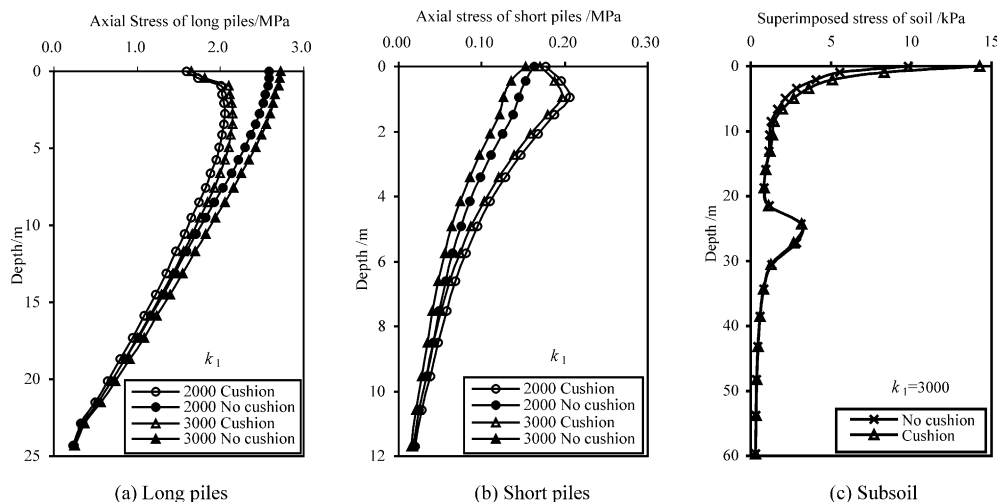

Fig. 6. Effects of cushion on load transfer mechanism of composite piled raft foundation.

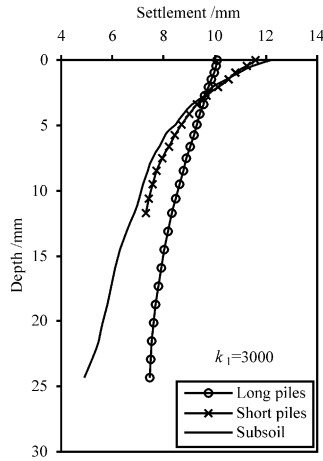

Fig. 7. Settlement of piles and subsoil of composite piled raft with cushion.

4.3. Effects of thickness of cushion on the properties of composite piled raft

In order to study the influence of cushion thickness, let $E_m = 80$ MPa (equivalent to $k_3 = 16$), $k_1 = 5000$ and $k_2 = 20$ with other parameters the same as the previous example. Fig. 10 shows the axial stress of piles along shafts changes with thickness of cushion. Fig. 11 shows that the superimposed stress of subsoil beneath the cushion as well as the vertical stress ratios of piles to subsoil change with the thickness of cushion. It can be seen from Figs. 10 and 11 that:

1. With the increasing of cushion thickness, the axial stress of long piles decreases gradually,

while the axial stress of short piles on the upper shaft increases first and then decreases along depth. Thus it can be deduced that there exists an optimum thickness of cushion, with which we can make best use of the capacities of short pile and subsoil and also alleviate the stress concentration of long piles effectively. In the example of this paper, the optimum thickness of cushion is about 0.4 m.

2. With the increasing of cushion thickness, the superimposed stress of subsoil among piles increases gradually, and the vertical stress ratio of long piles to subsoil decrease obviously, while that for short piles keeps almost constant. Thus it can be concluded that the thickness of cushion has considerable effects on the adjustment of the load-sharing ratio of piles to subsoil. But the effect of adjustment is decreasing with the increasing of cushion thickness.

5. Case study—a seven-story building

To validate the numerical results of this paper, a case history employing the conception of composite piled raft proposed by the authors is illustrated. The seven-story building is located nearby the Qiantang River. Some instruments were installed to observe the behavior of the composite piled raft foundation in situ.

Soil: Soil properties of the foundation are presented in the geotechnical investigation report for this building, which complies with Chinese Code for Investigation of Geotechnical Engineering (GB50021-2001). The main geological information of the foundation is quoted in Table 3, in which E_s is the elastic modulus

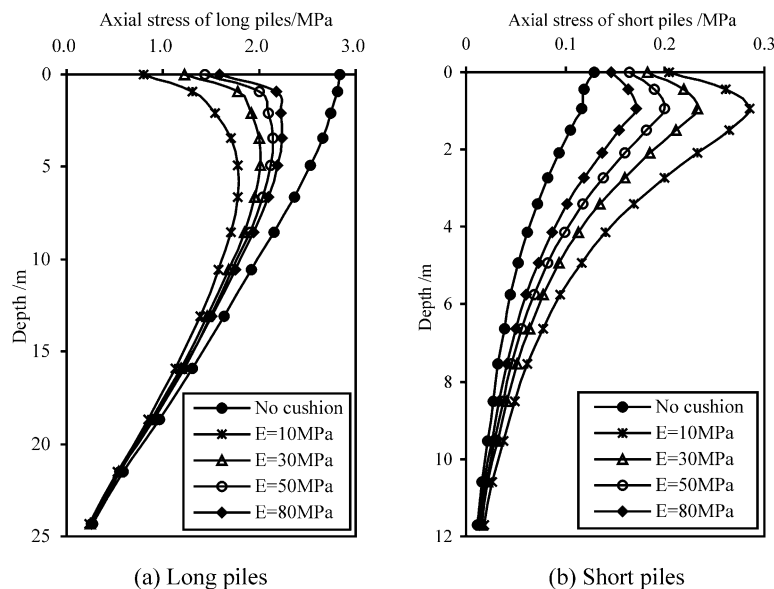

Fig. 8. Effects of cushion elastic modulus on axial stress distribution of piles.

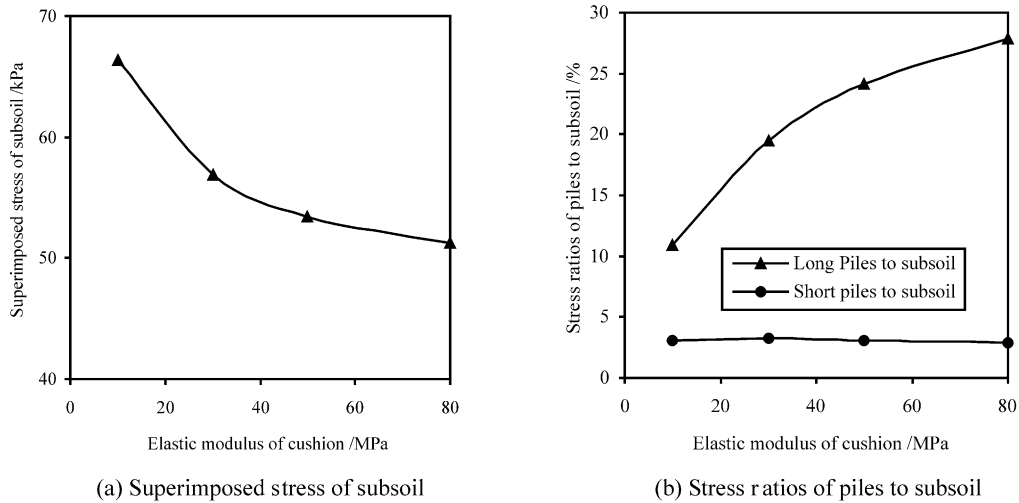

Fig. 9. Effects of cushion elastic modulus on the vertical stress ratio of piles to soil.

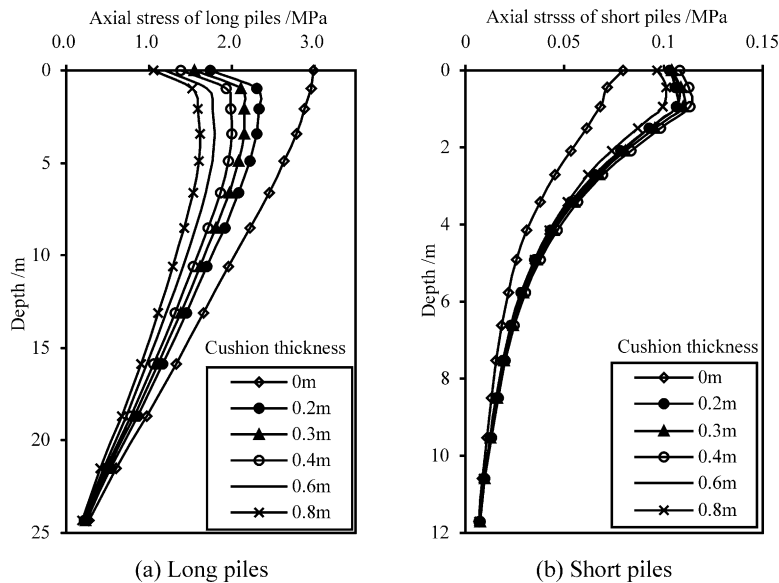

Fig. 10. Effects of cushion thickness on axial force of piles to soil.

assessed from the compression test of soil. Poisson’s ratio of soils is assumed to be 0.35.

Piles: soil–cement piles with 15% cement in weight, which have the diameter of 0.5 m, cement mixing depth of about 12.0 m and vertical allowable single

pile load capacity of not lower than 90 kN (equivalent to the allowable stress of 460 kPa), are used to improve the shallow subgrade. Driven cast-in-place piles embedded in stiff clays, which have diameter of 0.426 m, length of about 23.0 m and vertical allowable single pile load capacity of not lower than 350 kN (equivalent to the allowable stress of 2455 kPa), are used to reduce settlement. The elastic modulus and Poisson’s ratio of piles are summarized in Table 4.

Table 3
Geologic information of main subsoil layers for case study

Soil layer	Average thickness of layers /m	Water content /%	E_s /MPa
Silty clay	1.7	32.8	5.88
Silt	4.0	35.5	7.08
Mucky soil	11.9	48.7	2.38
Silty clay	3.1	33.1	5.87
Stiff clay	22.7	32.1	9.66
Weathered rock	/	21.8	9.87

Table 4
Properties of composite piled raft of the case history

Material	Long piles	Short piles	Cushion	Raft
Elastic Modulus/MPa	$E_{p1} = 2.8 \times 10^4$	$E_{p2} = 200$	$E_m = 25$	$E_c = 3.0 \times 10^4$
Poisson’s ratio	$\mu_{p1} = 0.20$	$\mu_{p2} = 0.25$	$\mu_m = 0.30$	$\mu_c = 0.20$

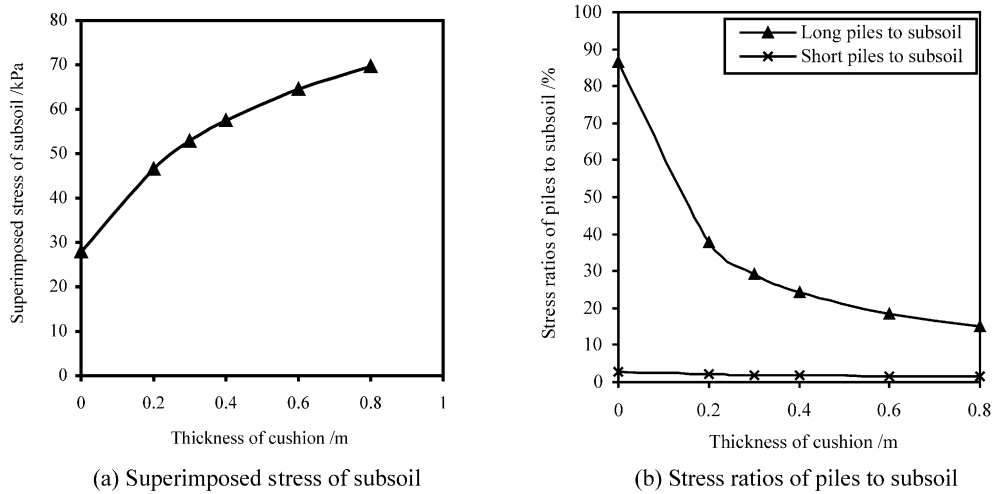

Fig. 11. Effects of cushion thickness on stress ratio of piles to soil.

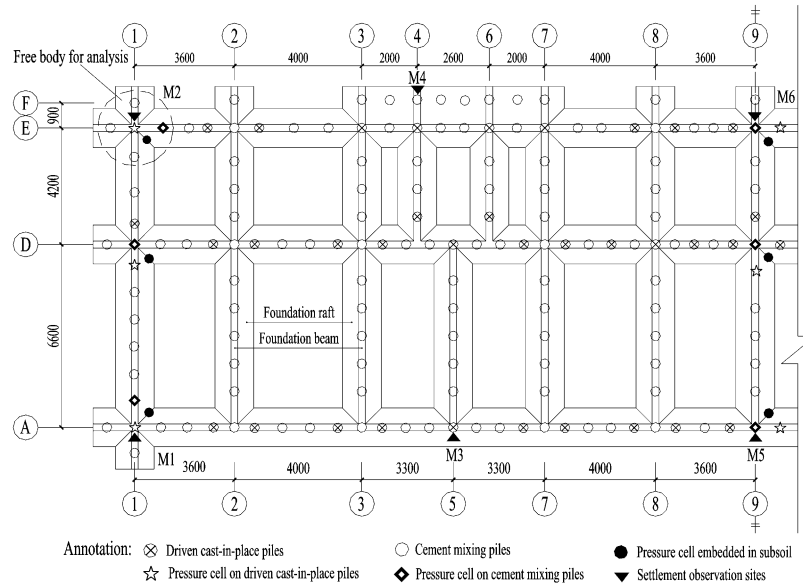

Fig. 12. Layout of piles and measuring instruments.

Cushion and Raft: The thickness of sand–gravel cushion and raft is 0.30 and 0.50 m, respectively. The elastic modulus and Poisson’s ratio of cushion and raft are also summarized in Table 4.

Loading: Effective plane area of the raft is 372 m² and the average distributed load acted on the raft is about 116 kPa, so the total design load of foundation is about 43.2 MN.

Layout of the piles and instruments for observation are shown in Fig. 12. To simplify the problem, only a part illustrated in Fig. 12 is isolated from the whole foundation as free body for analysis. Using similar calculation model

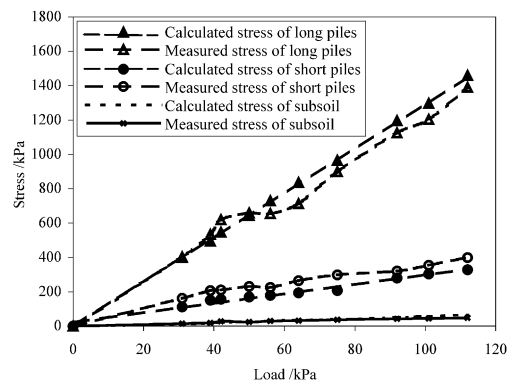

Fig. 13. Comparison of calculated results with observed data.

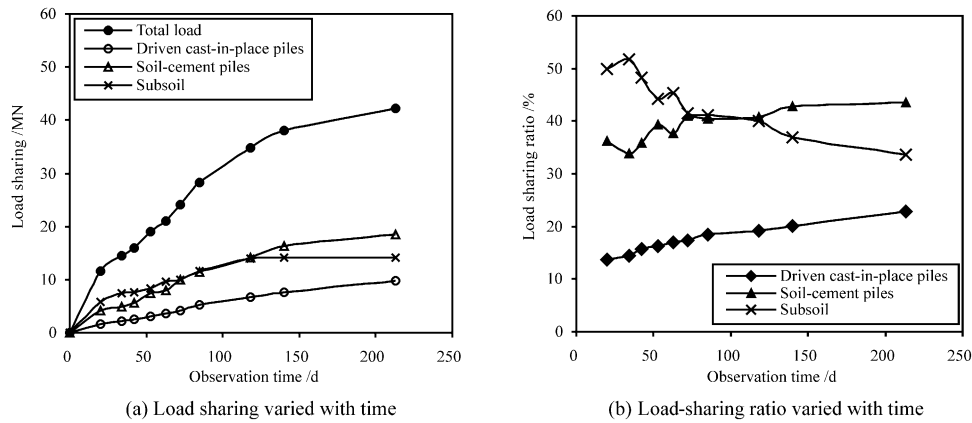

Fig. 14. Curves of observed load sharing of piles and subsoil.

proposed in this paper, Fig. 13 not only gives the curves of calculated stress of piles and subsoil vs. the applied load, but also compares them with the observed data. According to the observed data, the stress of piles is much lower than the allowable stress, so the piles are still in linear elastic stage. Though the influences of computational errors and actual nonlinear properties of soil exist, the comparison shows that the tendency of curves approximately conforms to the observed data.

Fig. 14 gives the curves of observed load sharing and load-sharing ratio of piles and subsoil. In the early stage of loading, the load-sharing ratio of subsoil is larger than 50%. With the increasing of total load, the load shared by subsoil increases very slowly, while the load-sharing ratio of subsoil decreases gradually. When the load increases to the finishing stage of major structure, the load shared by subsoil is almost not changed and the load-sharing ratio of subsoil is decreased to 30%. It means that the bearing capacities of shallow soil are exploited fully. The load shared by short piles increases gradually with the increasing of total load. When the load increases to the finishing stage of major structure, the load shared by short piles increases very slowly and the load-sharing ratio of short piles increases from 35 to 45%. The load shared by long piles increase almost linearly with the increasing of total load. When the load increases to the finishing stage of major structure, the load-sharing ratio of long piles increases from 15 to 25%. After the finishing stage of major structure, long piles mainly take on the increased load.

According to the curves of observed settlement vs. time shown in Fig. 15, the maximal and average settlement of foundation are 27 and 23 mm, respectively and tend towards convergence and stabilization. Therefore the settlement of foundation is controlled quite well and satisfies the performance of the building. The case history illustrates that the composite piled raft foundation can be applied to the subgrade with soft soil in the shallow layers. It has significant economic benefits on the foundation construction.

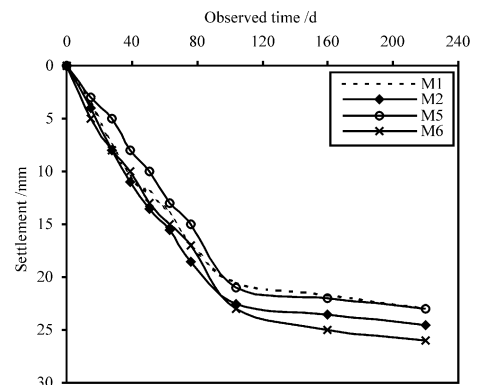

Fig. 15. Curves of observed settlement vs. time.

6. Summaries and conclusions

In order to apply conventional piled raft to the unfavorable situations, the authors introduced the concept of composite piled raft and incorporated the effect of unequal length and moduli of piles as well as the action of cushion in consideration. In this new type of foundation, the short piles are used to strengthen the shallow soft soil, the long piles are used to reduce the settlement and the cushion is used to redistribute and adjust the stress ratio of piles to subsoil. The advantages of different ground-improvement methodology were thus made good use. Three-dimensional finite element method was used to analyze it. The main factors influencing the bearing capacities and settlement behavior of the foundation are investigated. Based on the parametric study presented in this paper, the following conclusions are drawn out:

1. As far as influences of elastic modulus and length of piles are concerned, increasing lengths of long piles has much more obvious effects on reducing settlement of foundation than improving the elastic modulus of short piles. From the point of economy, there exists an optimum elastic modulus and length of piles for reducing settlement with the least cost.

2. Cushion can adjust the load-sharing ratios evenly among piles and help to make better use of the bearing capacities of short piles. Compared with the foundation without cushion, the maximum axial stress shifts lower from the head of piles to a certain depth. And the bearing capacities of shallow subsoil can be better used through appropriately applied cushion technique, especially for ground containing hard crust in shallow layers.
3. Decreasing the elastic modulus of cushion can decrease the stress concentration of long piles and mobilize the bearing capacity of short piles sufficiently.
4. There exists an optimum thickness of cushion to make best use of the capacities of short pile and subsoil as well as to alleviate the stress concentration of long piles effectively. The thickness of cushion has considerable effects on adjusting the load-sharing ratio of piles to subsoil.

The conclusion has been validated by a case history of seven-story building observed in situ. The results of this study have been adopted in the coastal cities of China. It can be used to guide the composite piled raft foundation design and has significant economic benefits.

Acknowledgements

The work reported here is supported by Shanghai Educational Development Foundation during 2001–2004 and Construction Bureau of Zhejiang Province of China. The authors wish to express their gratitude for the financial assistance. The anonymous reviewers' comments are also greatly acknowledged.

References

- [1] Poulos HG. Pile raft foundations: design and applications. *Geotechnique* 2001;51(2):95–113.
- [2] Davis EH, Poulos HG. The analysis of piled raft systems. *Australia Geotechnique Journal* 1972;2:21–7.
- [3] Burland JB, Broms BB, et al. Behavior of foundations and structures. *Proceeding 13th International Conference on Soil Mechanics and Foundation Engineering, Tokyo 1977*;2:495–546.
- [4] Cooke RW. Piled raft foundation on stiff clays—a contribution to design philosophy. *Geotechnique* 1986;36(2):169–203.
- [5] Chow YK, Thevendran V. Optimisation of pile groups. *Computers and Geotechnics* 1987;4:43–58.
- [6] Randolph MF. Design methods of pile group and piled rafts: state-of-the-art report. *Proceeding 13th International Conference on Soil Mechanics and Foundation Engineering, New Delhi 1994*;2:61–82.
- [7] Horikoshi K, Randolph MF. Centrifuge modeling of piled raft foundation on clay. *Geotechnique* 1996;46(4):741–52.
- [8] Ta LD, Small JC. Analysis of piled raft systems in layered soils. *International Journal for Numerical and Analytical Method in Geomechanics* 1996;20(1):57–72.
- [9] Kim KN, Lee SH, et al. Optimal pile arrangement for minimizing differential settlements in piled raft foundation. *Computers and Geotechnics* 2001;28(2):235–53.
- [10] Yang M. Study on reducing-settlement pile foundation based on controlling settlement principle. *Chinese Journal of Geotechnical Engineering* 2000;22(4):482–6.
- [11] Shahu JT, Madhav MR, Hayashi S. Analysis of soft ground-granular pile-granular mat system. *Computers and Geotechnics* 2001;27(1):45–62.
- [12] Ottaviani M. Three-dimensional finite element analysis of vertically loaded pile groups. *Geotechnique* 1975;25(2):159–74.
- [13] Lee CY. Settlement of pile groups—practical approach. *Journal of Geotechnical Engineering* 1993;119(5):1461–99.
- [14] Chow YK, Teh CI. Pile-cap-pile-group interaction in non-homogeneous soil. *Journal of Geotechnical Engineering* 1991;117(11):1655–68.
- [15] Schweiger HF. Numerical analysis of stone column supported foundations. *Computers and Geotechnics* 1986;2:347–72.